

MODEL NO  
C.W-S23301  
C.C.W-S23302

Specification:-

Type : Double acting hydraulic cylinder.  
Bore dia = 32 mm, rod dia 20 mm  
Clamp & Swing Stroke =10  
Operating pressure : max 150 bar/min 25 bar  
Medium :Hydraulic oil  
(servo system HLP46/HLP68)

- 1.0 GENERAL
- 1.1 ALL DIMENSIONS ARE IN MM.
- 1.2 DO NOT SCALE THE DRG.IF IN DOUBT ASK.
- 1.3 SUBJECT TO CHANGE FOR IMPROVEMENT.

| REVISION |     |      |    |      |
|----------|-----|------|----|------|
| ZONE     | REV | FROM | TO | DATE |
|          |     |      |    |      |
|          |     |      |    |      |
|          |     |      |    |      |

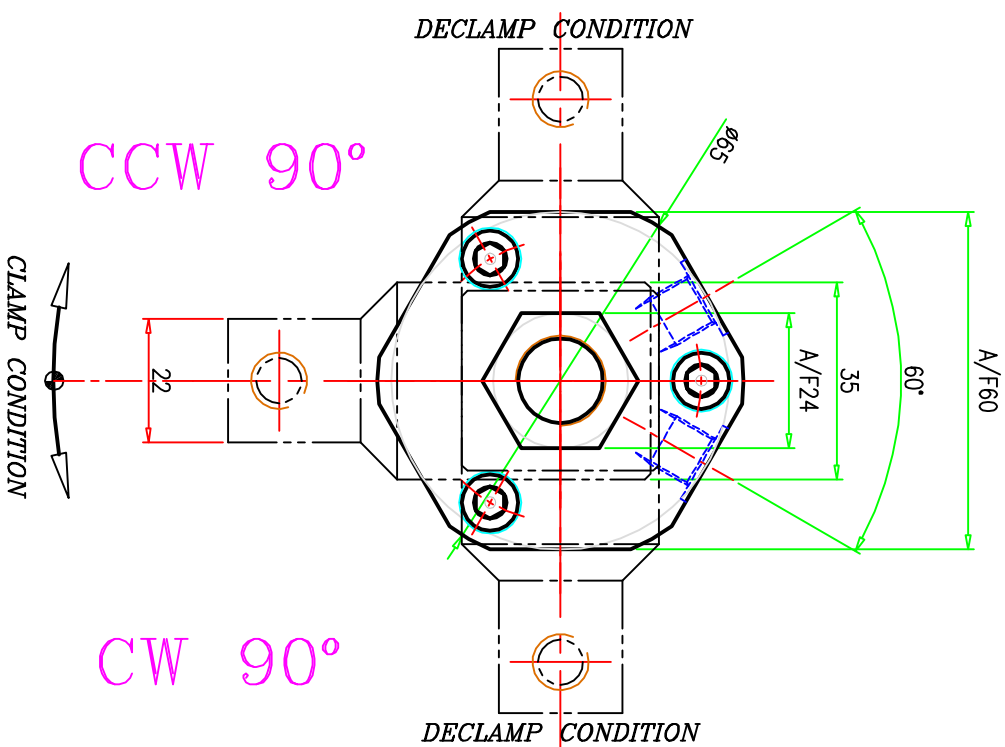

| SURFACE FINISH     |        | LINEAR - LENGTH OR DIAMETER            |        | ANGULAR-LENGTH IN MM OF SHORT SIDE OF ∠ |          |
|--------------------|--------|--|--------|---|----------|
| Ra value μm        | Symbol | 0.025                                  | 0.05   | 0.1                                     | 0.2      |
| 0.5-6              | ▽      | 6-30                                   | 30-120 | 120-315                                 | 315-1000 |
| ±0.1               | ▽      | ±0.2                                   | ±0.3   | ±0.5                                    | ±0.8     |
| SCALE: 1:1         |        | GENERAL TOLERANCES WHERE NOT SPECIFIED |        | UP TO 6                                 |          |
| TITLE: SWING CLAMP |        | MATERIAL: XXX                          |        | 6-30                                    |          |
| NAME: TIRUMAL      |        | DATE: 22.08.08                         |        | 6-30                                    |          |
| DESIGN: TIRUMAL    |        | MACHINE TYPE: THREADED BODY-D/A        |        | 50                                      |          |
| DRAWN: TIRUMAL     |        | CUSTOMER:                              |        | 100                                     |          |
| CHECKED:           |        | GROUP NO:                              |        | 30-120                                  |          |
| APPROVED:          |        | SUPERCEDED BY:                         |        | 120-400                                 |          |
|                    |        | DRAWING NO:                            |        | 30-120                                  |          |
|                    |        |  |        | 120-400                                 |          |

QUICLOC  
PVT LTD  
B'lore - 70

SHEET NO:  
1 OF: 1