

230(De-clamp condition)

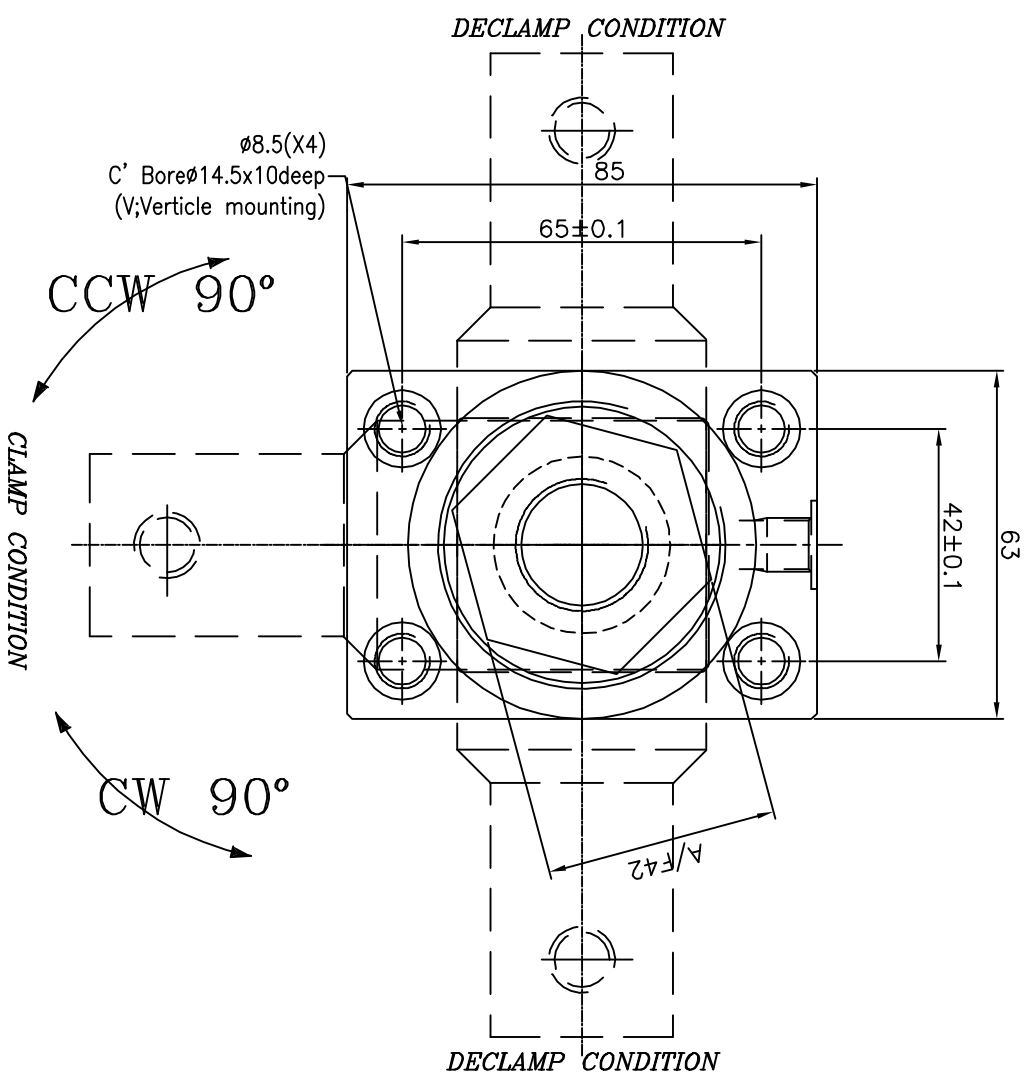

Specification:-

Type : Double acting hydraulic Block swing clamp
 Bore dia = 40 mm, rod dia = 32 mm
 Clamp Stroke =10;
 Zero vertical stroke during 90° horizontal swing
 Arm swing will be 90°±2°
 Operating pressure : max 100 bar/min 30 bar
 Medium :Hydraulic oil
 (servo system HLP46/HLP68)

Model NO-C.W-S12303
 C.C.W-S12304

- 1.0 GENERAL
 1.1 ALL DIMENSIONS ARE IN MM.
 1.2 DO NOT SCALE THE DRG.IF IN DOUBT ASK.
 1.3 SUBJECT TO CHANGE FOR IMPROVEMENT.

SURFACE FINISH		LINEAR - LENGTH OR DIAMETER		ANGULAR-LENGTH IN MM OF SHORT SIDE OF ∠								
Ra value μm	Symbol	0.5-6	6-30	30-120	120-315	315-1000	1000-2000	UP TO 6	6-30	30-120	120-400	
0.025	▽▽▽	0.1	0.2	0.4	0.8	1.6	3.2	6.3	12.5	25	50	100
GENERAL TOLERANCES WHERE NOT SPECIFIED												
SCALE: 1:1												
TITLE: BLOCK SWING CLAMP												
DOUBLE ACTING												
MATERIAL: XXX												
GROUP NO: XXX												
SUPERCEDED BY: -												
DRAWING NO: -												
SHEET NO: 1 OF 1												
QUICLOC PVT LTD Blore - 70												

REVISION				
ZONE	REV	FROM	TO	DATE

1 2 3 4 5 6 7 8

F E D C B A