

1

2

3

4

A

A

B

B

C

C

D

D

E

E

F

F

SHEET FORMATS-1, FORMAT NO: F-8-DGN-10, Sht1 of 2 DT.01-11-05 Rew No-00-A4

REVISION					
ZONE	REV	FROM	TO	DATE	APPROVED

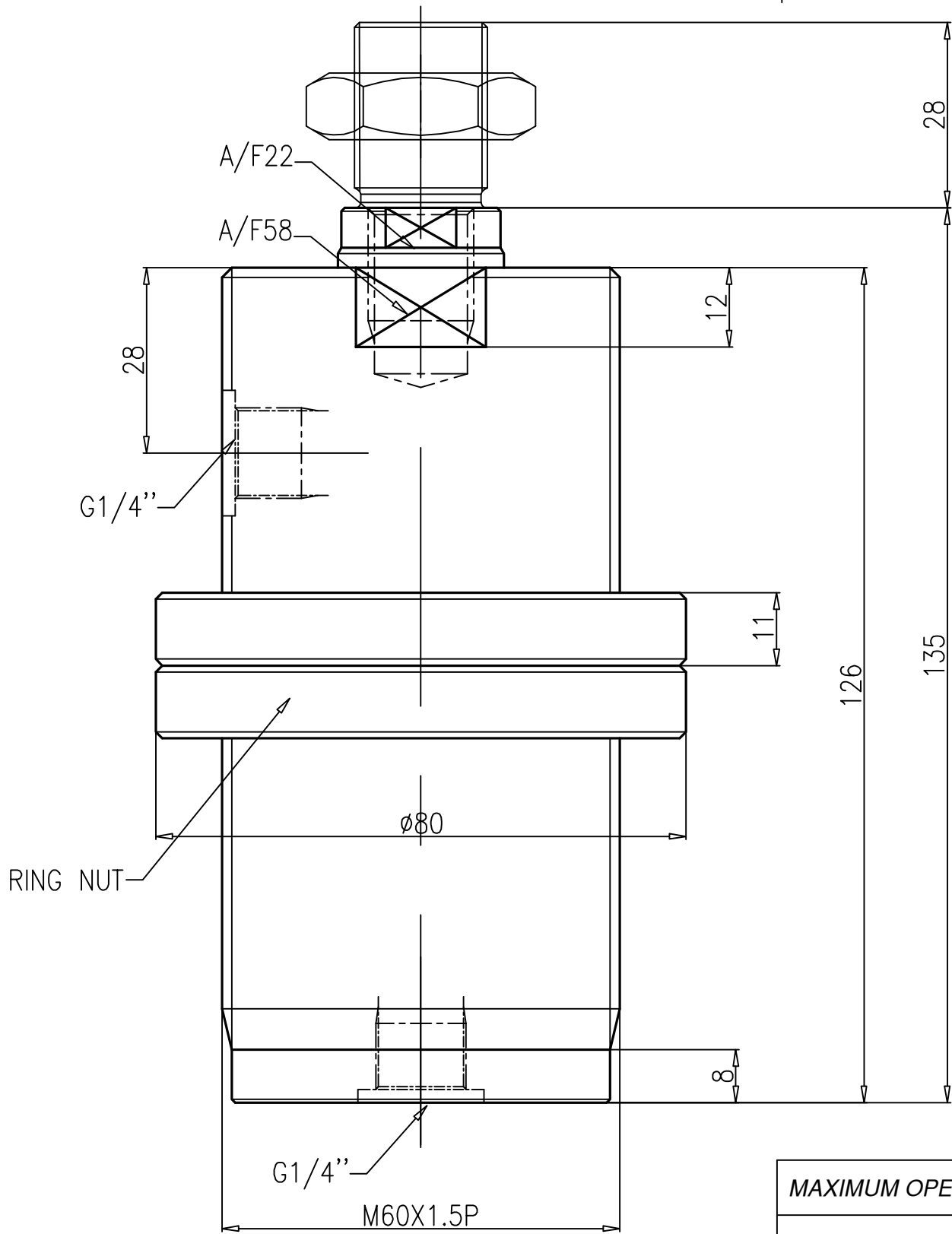

MAXIMUM OPEARATING PRESSURE	250 BAR
MINIMUM OPEARATING PRESSURE	10 BAR
STROKE	40 MM
DISPLACEMENT IN CC	50 cc
PISTON AREA	12 SQ.CM

1.0 GENERAL

- 1.1 ALL DIMENSIONS ARE IN MM.
- 1.2 DO NOT SCALE THE DRG. IF IN DOUBT ASK.
- 1.3 ROUND OF THE UNSPECIFIED EDGES.

SURFACE FINISH													
Ra value μm	0.025	0.05	0.1	0.2	0.4	0.8	1.6	3.2	6.3	12.5	25	50	100

GENERAL TOLERANCES WHERE NOT SPECIFIED

LINEAR - LENGTH OR DIAMETER						ANGULAR-LENGTH IN MM OF SHORT SIDE OF ∠			
0.5-6	6-30	30-120	120-315	315-1000	1000-2000	UPTO 6	6-30	30-120	120-400
±0.1	±0.2	±0.3	±0.5	±0.8	±1.2	±1'	±30'	±20'	±10'

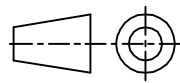

**QUICLOC  
PVT LTD  
B'lore - 70**

SCALE <b>1;1</b>	TITLE <b>MINI THREADED BODY CYLINDER D/A</b>	MATERIAL <b>XXX</b>	SHEET NO 1 OF 1
NAME <b>TIRUMAL</b>	DATE <b>28-10-05</b>	GROUP NO.	REPLACES
DESIGN	DATE <b>14-11-05</b>	SUPERCEDED BY -	REPLACES -
DRAWN	CUSTOMER:	DRAWING NO. <b>A52307</b>	
CHECKED			
APPROVED			

1

2

3

4