

1

2

3

4

A

A

B

B

C

C

D

D

E

E

F

F

SHEET FORMATS-1, FORMAT NO: F-8-DGN-10, Sht1 of 2 DT.01-11-05 Rew No-00-A4

REVISION					
ZONE	REV	FROM	TO	DATE	APPROVED

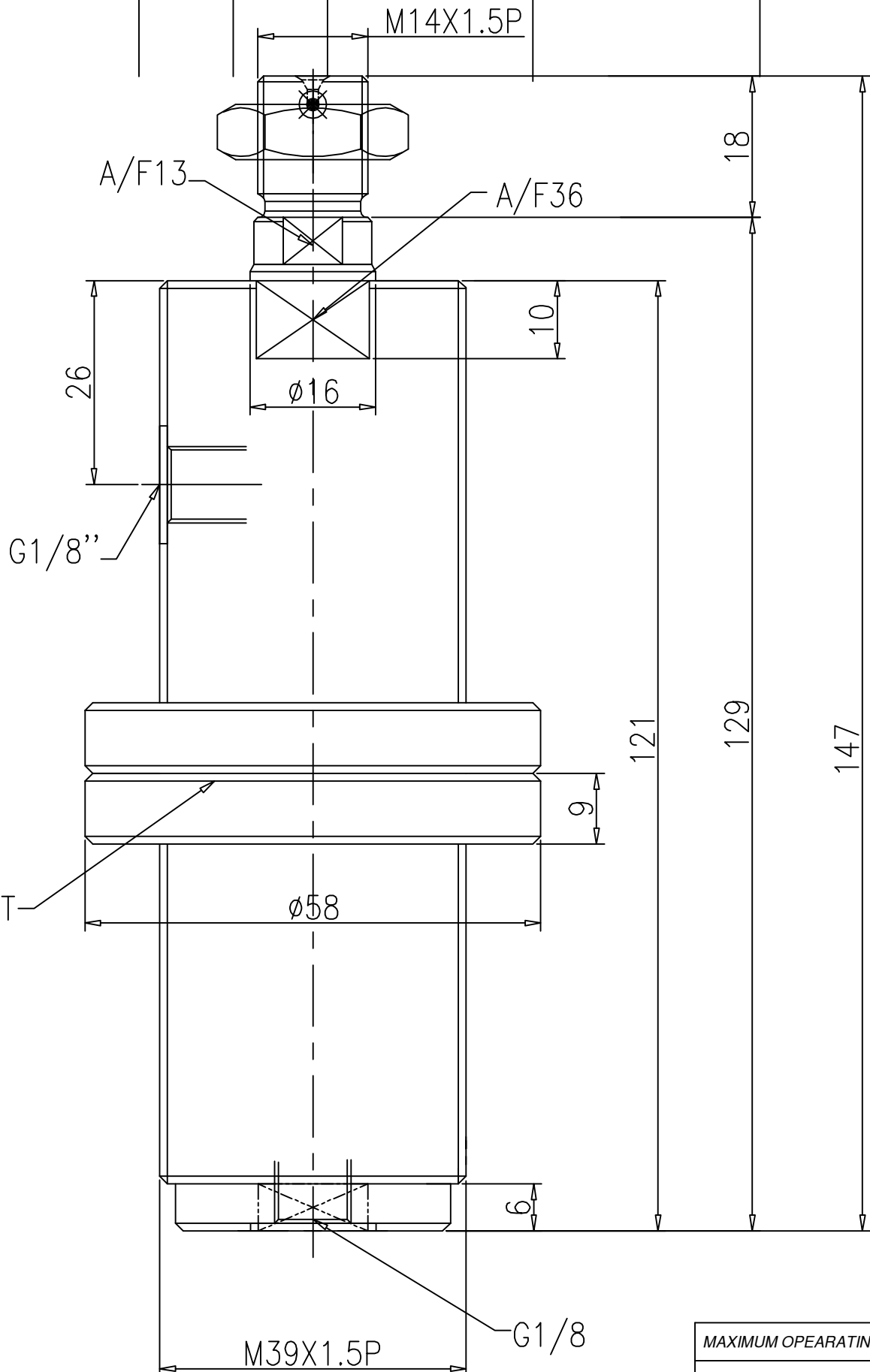

1.0 GENERAL

- 1.1 ALL DIMENSIONS ARE IN MM.
- 1.2 DO NOT SCALE THE DRG. IF IN DOUBT ASK.
- 1.3 ROUND OFF THE UNSPECIFIED EDGES.
- 1.4 DEBURR ALL OVER.

MAXIMUM OPERATING PRESSURE	250 BAR
MINIMUM OPERATING PRESSURE	10 BAR
STROKE	40 MM
DISPLACEMENT IN CC	19.5 cc
PISTON AREA	4.9 SQ.CM

SURFACE FINISH													
Ra value μm	0.025	0.05	0.1	0.2	0.4	0.8	1.6	3.2	6.3	12.5	25	50	100

GENERAL TOLERANCES WHERE NOT SPECIFIED

LINEAR - LENGTH OR DIAMETER						ANGULAR-LENGTH IN MM OF SHORT SIDE OF ∠			
0.5-6	6-30	30-120	120-315	315-1000	1000-2000	UPTO 6	6-30	30-120	120-400
±0.1	±0.2	±0.3	±0.5	±0.8	±1.2	±1'	±30'	±20'	±10'

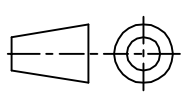

**QUICLOC
PVT LTD
B'lore - 70**

SCALE	1:1	TITLE	MINI THREADED BODY CYLINDER D/A		MATERIAL	XXX	SHEET NO	1 OF 1
DESIGN	TIRUMAL	DATE	28-10-05	MACHINE TYPE	GROUP NO.			
DRAWN	TIRUMAL	DATE	24-03-06		SUPERCEDED BY	REPLACES		
CHECKED				CUSTOMER:	DRAWING NO.	A52303		
APPROVED								

1

2

3

4