

1

2

3

4

A

A

B

B

C

C

D

D

E

E

F

F

SHEET FORMATS-1, FORMAT NO: F-8-DGN-109, DT.01-11-05 Rew No-00-A4

| REVISION |     |      |    |      |          |
|----------|-----|------|----|------|----------|
| ZONE     | REV | FROM | TO | DATE | APPROVED |
|          |     |      |    |      |          |

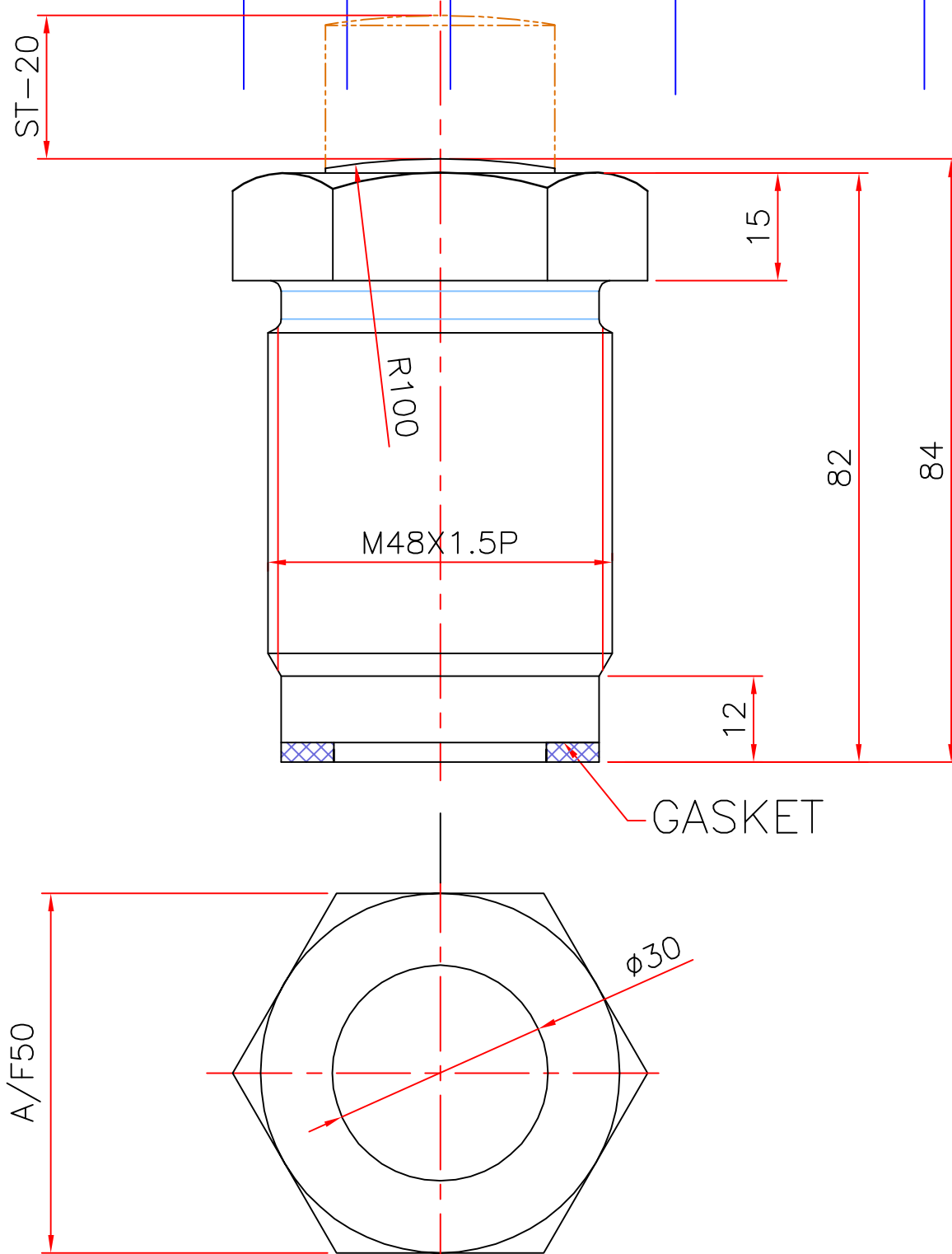
**Specification:-**

Type : Single acting hydraulic cylinder.  
 Ram dia - 32mm  
 Stroke - 20 mm  
 Operating pressure : max 200 bar/min 5 bar  
 Medium :Hydraulic oil  
 (servo system HLP46/HLP68)

**1.0 GENERAL**

- 1.1 ALL DIMENSIONS ARE IN MM.
- 1.2 DO NOT SCALE THE DRG. IF IN DOUBT ASK.
- 1.3 SUBJECT TO CHANGE FOR IMPROVEMENT.

| SURFACE FINISH         |       |      |     |     |     |     |     |     |     |      |    |    |     |
|------------------------|-------|------|-----|-----|-----|-----|-----|-----|-----|------|----|----|-----|
| Ra value $\mu\text{m}$ | 0.025 | 0.05 | 0.1 | 0.2 | 0.4 | 0.8 | 1.6 | 3.2 | 6.3 | 12.5 | 25 | 50 | 100 |

GENERAL TOLERANCES WHERE NOT SPECIFIED

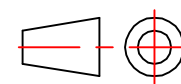

**QUICLOC  
PVT LTD  
B'lore - 70**

| LINEAR - LENGTH OR DIAMETER |           |           |           |           |           | ANGULAR-LENGTH IN MM OF SHORT SIDE OF $\angle$ |           |           |           |
|-----------------------------|-----------|-----------|-----------|-----------|-----------|--|-----------|-----------|-----------|
| 0.5-6                       | 6-30      | 30-120    | 120-315   | 315-1000  | 1000-2000 | UPTO 6   | 6-30      | 30-120    | 120-400   |
| $\pm 0.1$                   | $\pm 0.2$ | $\pm 0.3$ | $\pm 0.5$ | $\pm 0.8$ | $\pm 1.2$ | $\pm 1'$                                       | $\pm 30'$ | $\pm 20'$ | $\pm 10'$ |

|                          |   |                           |                              |
|--------------------------|---|---------------------------|------------------------------|
| SCALE<br><b>xxx</b>      | TITLE<br><b>MANIFOLD THREADED<br/>BODY CYL (S/A)</b>    | MATERIAL<br><b>xxx</b>    | SHEET NO<br><b>1 OF 1</b>    |
| DESIGN<br><b>TIRUMAL</b> | DATE<br><b>27.08.08</b>                                 | GROUP NO.                 | REPLACES                     |
| DRAWN<br><b>TIRUMAL</b>  | MACHINE TYPE<br><b>INTERNAL THREADED PISTON ROD END</b> | SUPERCEDED BY<br><b>-</b> | DRAWING NO.<br><b>A12205</b> |
| CHECKED                  | CUSTOMER:   |                           |                              |
| APPROVED                 |   |                           |                              |

1

2

3

4