

1

2

3

4

A

A

B

B

C

C

D

D

E

E

F

F

SHEET FORMATS-1,FORMAT NO: F-8-DGN-109, DT.01-11-05 Rew No-00-A4

REVISION

ZONE	REV	FROM	TO	DATE	APPROVED

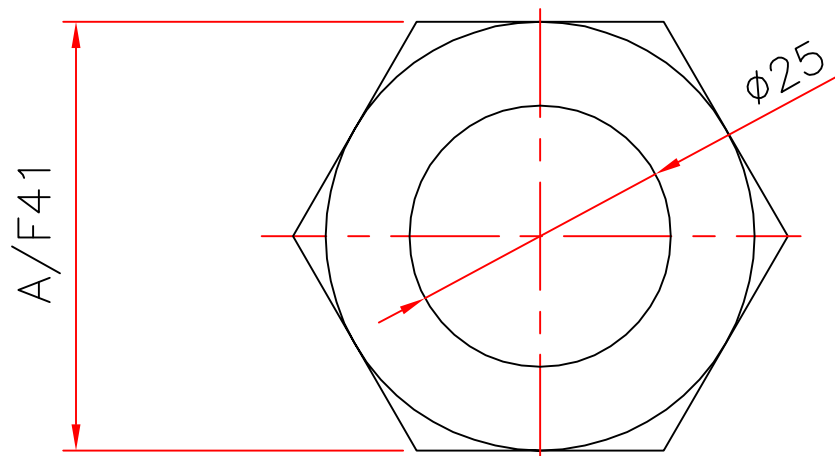
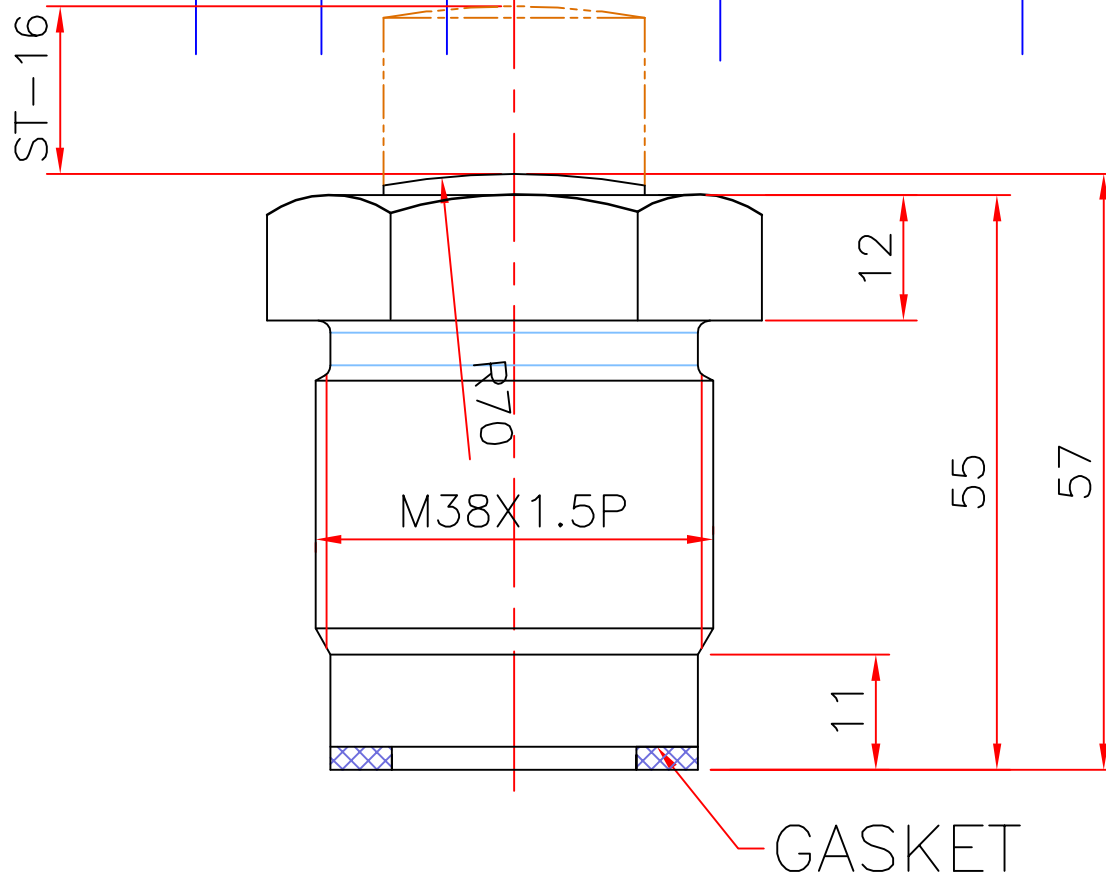
**Specification:-**

Type : Single acting hydraulic cylinder.

Ram dia - 25 mm

Stoke - 16 mm

Operating pressure : max 200 bar/min 5 bar

Medium :Hydraulic oil
(servo system HLP46/HLP68)**1.0 GENERAL**

- 1.1 ALL DIMENSIONS ARE IN MM.
- 1.2 DO NOT SCALE THE DRG. IF IN DOUBT ASK.
- 1.3 SUBJECT TO CHANGE FOR IMPROVEMENT.

SURFACE FINISH

Ra value μm

▽▽▽▽

▽▽▽

▽▽

▽

~

0.025 0.05 0.1

0.2 0.4 0.8

1.6 3.2 6.3

12.5 25 50 100

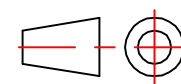

GENERAL TOLERANCES WHERE NOT SPECIFIED

LINEAR - LENGTH OR DIAMETER

ANGULAR-LENGTH IN MM OF SHORT SIDE OF \angle

0.5-6

6-30

30-120

120-315

315-1000

1000-2000

UPTO 6

6-30

30-120

120-400

 ± 0.1 ± 0.2 ± 0.3 ± 0.5 ± 0.8 ± 1.2 $\pm 1'$ $\pm 30'$ $\pm 20'$ $\pm 10'$

QUICLOC
PVT LTD
B'lore - 70

SCALE

xxx

-

TITLE

MANIFOLD THREADED**BODY CYL (S/A)**

MATERIAL

xxx

SHEET NO

1 OF 1

NAME

TIRUMAL

DATE

27.08.08

GROUP NO.

-

REPLACES

-

DESIGN

TIRUMAL

MACHINE TYPE

INTERNAL THREADED PISTON ROD END

DRAWING NO.

A12203

CHECKED

APPROVED

1

2

3

4