

1

2

3

4

A

A

B

B

C

C

D

D

E

E

F

F

SHEET FORMATS-1, FORMAT NO: F-8-DGN-109, DT.01-11-05 Rew No-00-A4

REVISION					
ZONE	REV	FROM	TO	DATE	APPROVED

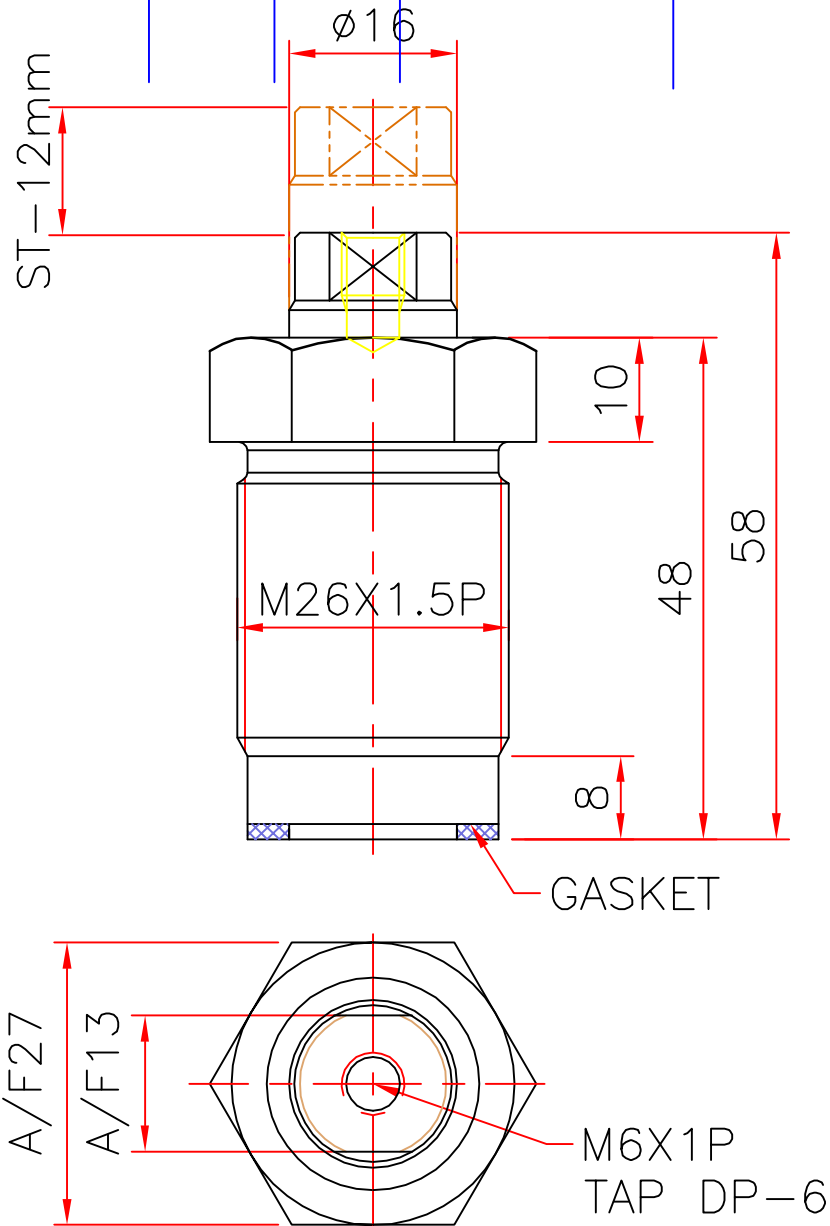

Specification:-

Type : Single acting hydraulic cylinder.

Ram dia -16 mm

Stroke - 12mm

Operating pressure : max 200 bar/min 5 bar

Medium :Hydraulic oil
(servo system HLP46/HLP68)

1.0 GENERAL

- 1.1 ALL DIMENSIONS ARE IN MM.
- 1.2 DO NOT SCALE THE DRG.IF IN DOUBT ASK.
- 1.3 SUBJECT TO CHANGE FOR IMPROVEMENT.

SURFACE FINISH														
Ra value	µm	0.025	0.05	0.1	0.2	0.4	0.8	1.6	3.2	6.3	12.5	25	50	100

GENERAL TOLERANCES WHERE NOT SPECIFIED

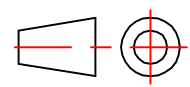

QUICLOC
PVT LTD
B'lore - 70

LINEAR - LENGTH OR DIAMETER						ANGULAR-LENGTH IN MM OF SHORT SIDE OF ∠			
0.5-6	6-30	30-120	120-315	315-1000	1000-2000	UPTO 6	6-30	30-120	120-400
±0.1	±0.2	±0.3	±0.5	±0.8	±1.2	±1'	±30'	±20'	±10'

SCALE	XXX		TITLE	MANIFOLD THREADED			MATERIAL	SHEET NO	
DESIGN	TIRUMAL	DATE	MACHINE TYPE			GROUP NO.	1 OF 1		
DRAWN	TIRUMAL	27.08.08							
CHECKED			CUSTOMER:			SUPERCEDED BY	REPLACES		
APPROVED						DRAWING NO.	A12202		

1

2

3

4