

1

2

3

4

A

A

B

B

C

C

D

D

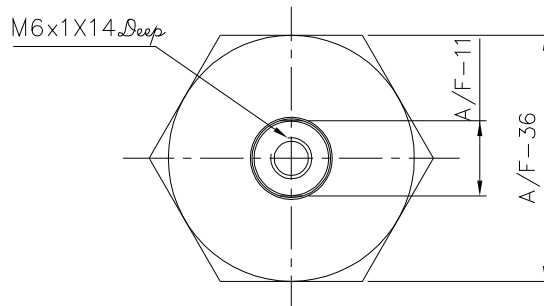
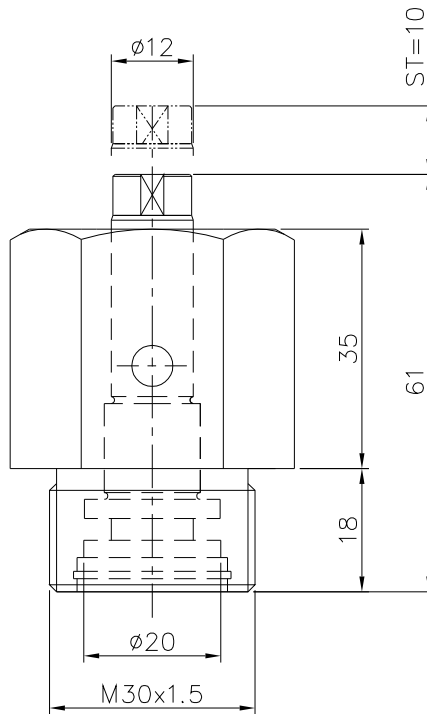

1.0 GENERAL

- 1.1 ALL DIMENSIONS ARE IN MM.
- 1.2 DO NOT SCALE THE DRG. IF IN DOUBT ASK.
- 1.3 ROUND OFF THE UNSPECIFIED EDGES.
- 1.4 DEBURR ALL OVER.

E

E

SURFACE FINISH														
Ra value μm		0.025	0.05	0.1	0.2	0.4	0.8	1.6	3.2	6.3	12.5	25	50	100
GENERAL TOLERANCES WHERE NOT SPECIFIED														
LINEAR - LENGTH OR DIAMETER						ANGULAR-LENGTH IN MM OF SHORT SIDE OF \angle					QUICLOC PVT LTD B'lore - 70			
0.5-6	6-30	30-120	120-315	315-1000	1000-2000	UPTO 6	6-30	30-120	120-400					
± 0.1	± 0.2	± 0.3	± 0.5	± 0.8	± 1.2	$\pm 1'$	$\pm 30'$	$\pm 20'$	$\pm 10'$					
SCALE 1:1		TITLE MANIFOLD THREADED CYLINDER S/A				MATERIAL		SHEET NO 1 OF 1						
NAME		DATE		MACHINE TYPE				GROUP NO.		REPLACES				
DESIGN	TIRUMAL	20-02-02												
DRAWN	THYAGA	12-12-02		CUSTOMER:				SUPERCEDED BY		DRAWING NO. A11204				
CHECKED														
APPROVED														

F

F

1

2

3

4