

1

2

3

4

A

A

B

B

C

C

D

D

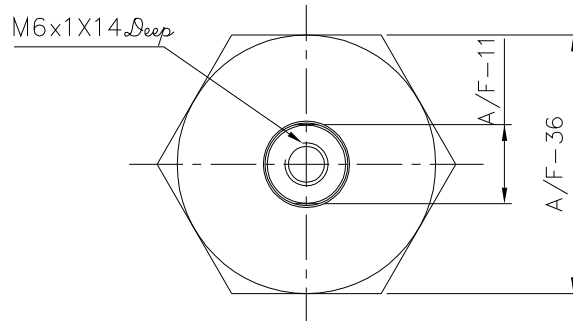
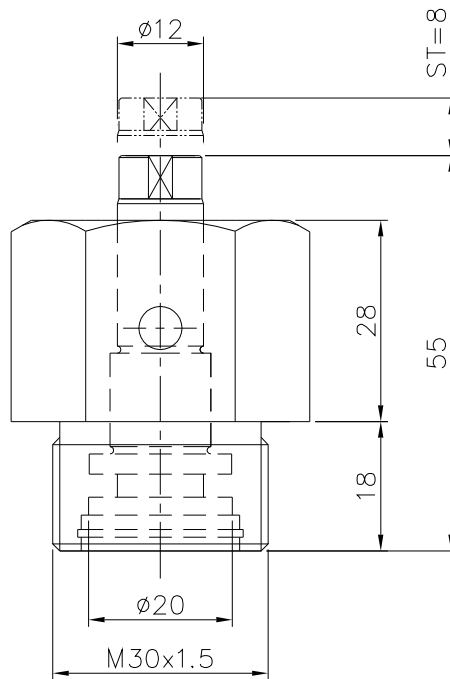

1.0 GENERAL

- 1.1 ALL DIMENSIONS ARE IN MM.
- 1.2 DO NOT SCALE THE DRG. IF IN DOUBT ASK.
- 1.3 ROUND OFF THE UNSPECIFIED EDGES.
- 1.4 DEBURR ALL OVER.

E

E

SURFACE FINISH		▽▽▽▽	▽▽▽	▽▽	▽	~								
Ra value μm		0.025	0.05	0.1	0.2	0.4	0.8	1.6	3.2	6.3	12.5	25	50	100
GENERAL TOLERANCES WHERE NOT SPECIFIED														
LINEAR - LENGTH OR DIAMETER							ANGULAR-LENGTH IN MM OF SHORT SIDE OF ∠							
0.5-6	6-30	30-120	120-315	315-1000	1000-2000	UPTO 6	6-30	30-120	120-400					
±0.1	±0.2	±0.3	±0.5	±0.8	±1.2	±1'	±30'	±20'	±10'					
SCALE 1:1		TITLE MANIFOLD THREADED CYLINDER S/A				MATERIAL				SHEET NO 1 OF 1				
		NAME TIRUMAL		DATE 20-02-02		GROUP NO.				SUPERCEDED BY				
DESIGN		DRAWN		CHECKED		APPROVED		MACHINE TYPE				REPLACES		
		THYAGA		26-12-12		CUSTOMER:				DRAWING NO. A11203				

F

F

1

2

3

4