

1

2

3

4

A

A

B

C

D

E

F

REVISION

ZONE	REV	FROM	TO	DATE	APPROVED

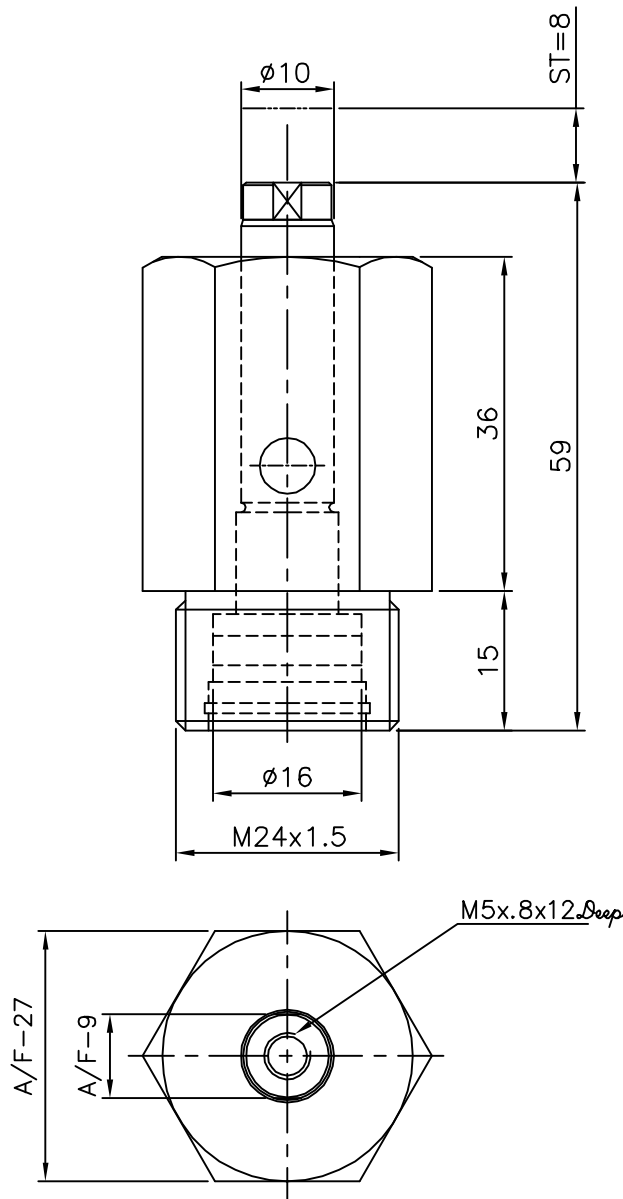

1.0 GENERAL

1.1 ALL DIMENSIONS ARE IN MM.

1.2 DO NOT SCALE THE DRG. IF IN DOUBT ASK.

SURFACE FINISH		▽▽▽▽	▽▽▽	▽▽	▽	~								
Ra value μm		0.025	0.05	0.1	0.2	0.4	0.8	1.6	3.2	6.3	12.5	25	50	100

GENERAL TOLERANCES WHERE NOT SPECIFIED

LINEAR - LENGTH OR DIAMETER						ANGULAR-LENGTH IN MM OF SHORT SIDE OF ∠			
0.5-6	6-30	30-120	120-315	315-1000	1000-2000	UPTO 6	6-30	30-120	120-400
±0.1	±0.2	±0.3	±0.5	±0.8	±1.2	±1'	±30'	±20'	±10'

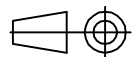

QUICLOC
PVT LTD
B'lore - 70

SCALE

1:1

TITLE

MANIFOLD THREADED
CYLINDER S/A

MATERIAL

SHEET NO

1 OF 1

DESIGN

TIRUMAL

DRAWN

THYAGA

CHECKED

APPROVED

NAME

THYAGA

DATE

MACHINE TYPE

CUSTOMER:

GROUP NO.

SUPERCEDED BY

DRAWING NO.

REPLACES

A11202

1

2

3

4

E

F