

1

2

3

4

A

A

B

C

D

E

F

REVISION						
ZONE	REV	FROM	TO	DATE	APPROVED	

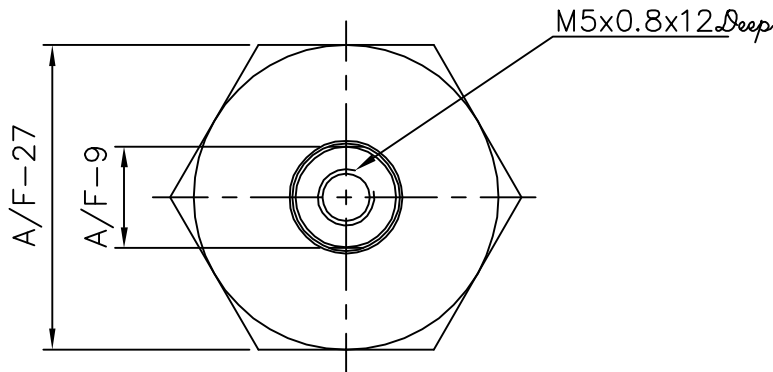
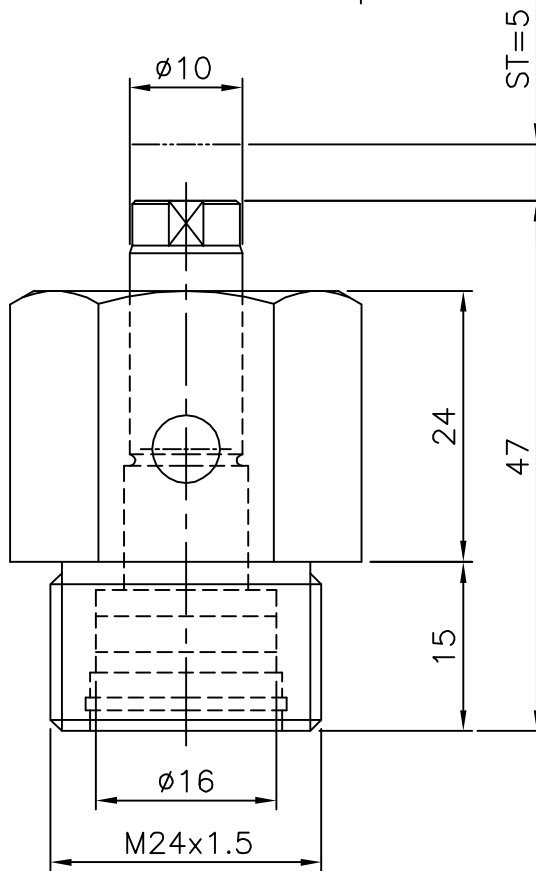

1.0 GENERAL

- 1.1 ALL DIMENSIONS ARE IN MM.
- 1.2 DO NOT SCALE THE DRG. IF IN DOUBT ASK.

SURFACE FINISH		▽▽▽▽	▽▽▽	▽▽	▽	~								
Ra value μm		0.025	0.05	0.1	0.2	0.4	0.8	1.6	3.2	6.3	12.5	25	50	100
GENERAL TOLERANCES WHERE NOT SPECIFIED														
LINEAR - LENGTH OR DIAMETER							ANGULAR-LENGTH IN MM OF SHORT SIDE OF ∠							
0.5-6	6-30	30-120	120-315	315-1000	1000-2000	UPTO 6	6-30	30-120	120-400					
±0.1	±0.2	±0.3	±0.5	±0.8	±1.2	±1'	±30'	±20'	±10'					

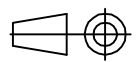

**QUICLOC
PVT LTD
B'lore - 70**

SCALE 1:1		TITLE MANIFOLD THREADED CYLINDER S/A				MATERIAL		SHEET NO 1 OF 1	
DESIGN	TIRUMAL	MACHINE TYPE				GROUP NO.		REPLACES	
DRAWN	THYAGA	CUSTOMER:				SUPERCEDED BY			
CHECKED						DRAWING NO.		A11201	
APPROVED									

1

2

3

4