

SHORT STROKE (S)

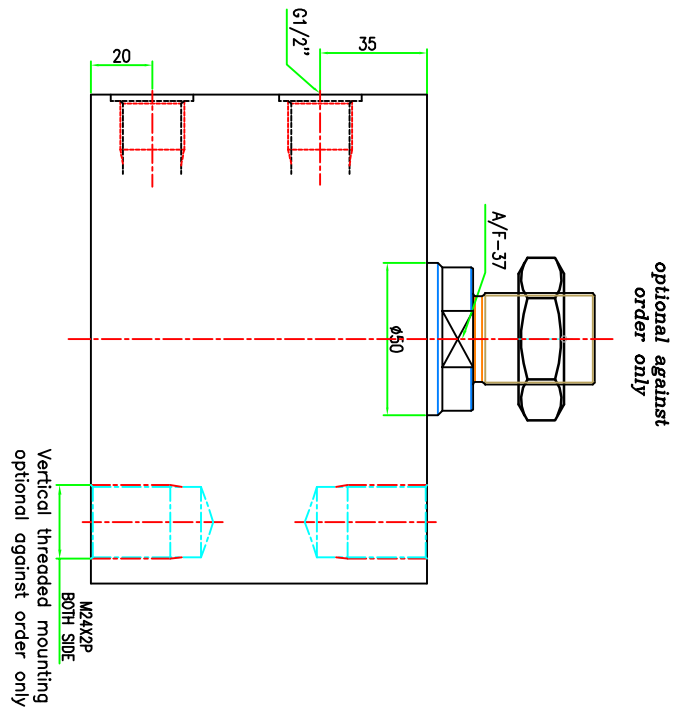

C BORE#33XDEEP-22
#22(X4)THR U

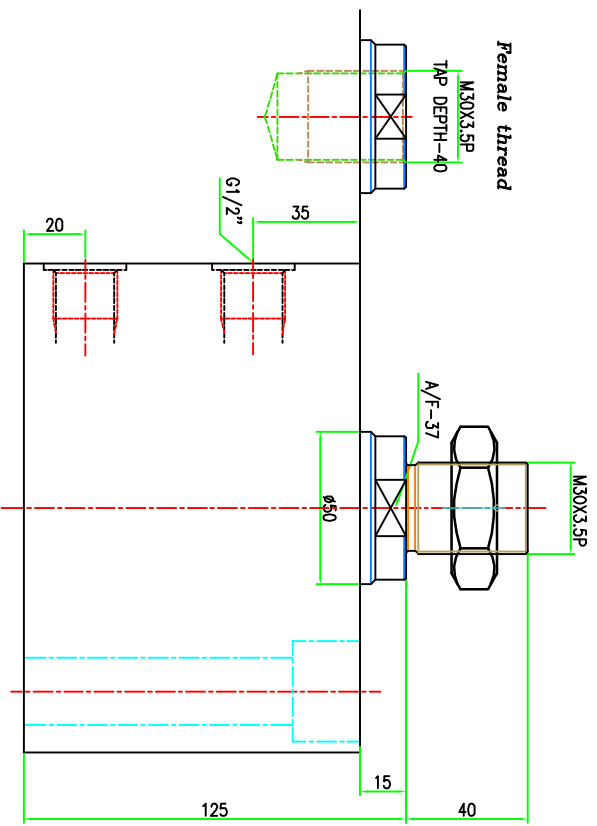
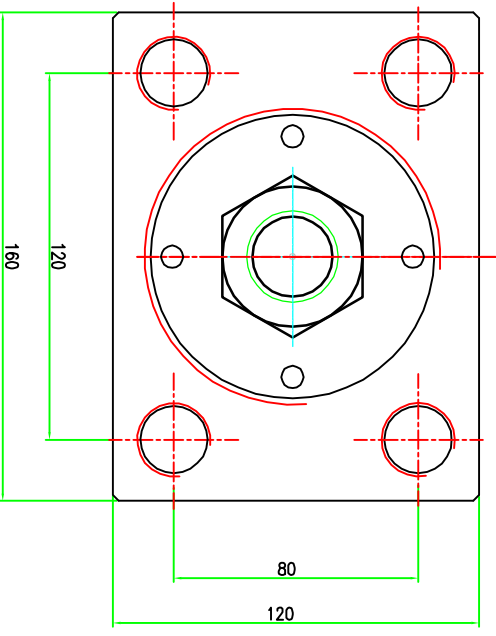
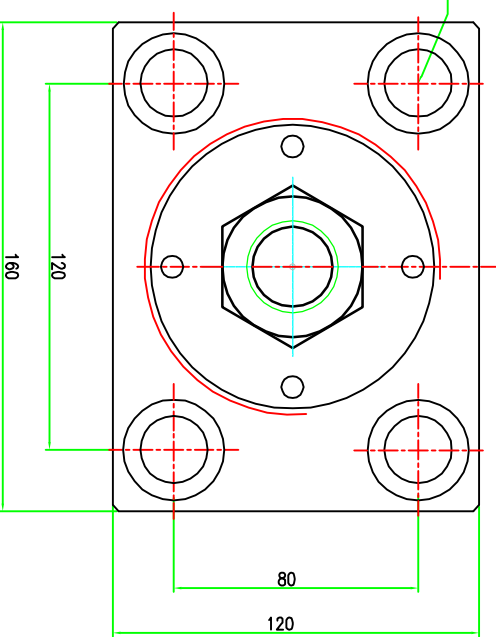

Model NO-Male thread-A31313
Female thread-A31314

Specification:-
Type : Double acting hydraulic cylinder.
Bore dia = 80 mm, rod dia = 50 mm
Stroke = 25 mm
Operating pressure : max 250 bar/min 10 bar
Medium :Hydraulic oil (servo system HLP46/HLP68)

- 1.0 GENERAL
- 1.1 ALL DIMENSIONS ARE IN MM.
- 1.2 DO NOT SCALE THE DRG.IF IN DOUBT ASK.
- 1.3 SUBJECT TO CHANGE FOR IMPROVEMENT.

REVISION				
ZONE	REV	FROM	TO	DATE

SURFACE FINISH	0.025	0.05	0.1	0.2	0.4	0.8	1.6	3.2	6.3	12.5	25	50	100
Ra value μm	0.025	0.05	0.1	0.2	0.4	0.8	1.6	3.2	6.3	12.5	25	50	100

GENERAL TOLERANCES WHERE NOT SPECIFIED		ANGULAR-LENGTH IN MM OF SHORT SIDE OF ∠								
LINEAR - LENGTH OR DIAMETER	0.5-6	6-30	30-120	120-315	315-1000	1000-2000	UP TO 6	6-30	30-120	120-400
±0.1	±0.2	±0.3	±0.5	±0.8	±1.2	±1'	±1'	±30'	±20'	±10'

SCALE: 1:1	TITLE: BLOCK CYLINDER DOUBLE ACTING	MATERIAL: XXX	SHEET NO: 1 OF 1
DESIGN: TIRUMAL 22.08.08	MACHINE TYPE	GROUP NO:	REPLACES
DRAWN: TIRUMAL 22.08.08	CUSTOMER:	SUPERCEDED BY	
CHECKED:		DRAWING NO:	
APPROVED:			

QUICLOC
PVT LTD
B'lore - 70