

1

2

3

4

A

A

B

B

C

C

D

D

E

E

F

F

SHEET FORMATS-1, FORMAT NO: F-8-DGN-109, DT.01-11-05 Rew No-00-A4

REVISION

ZONE	REV	FROM	TO	DATE	APPROVED

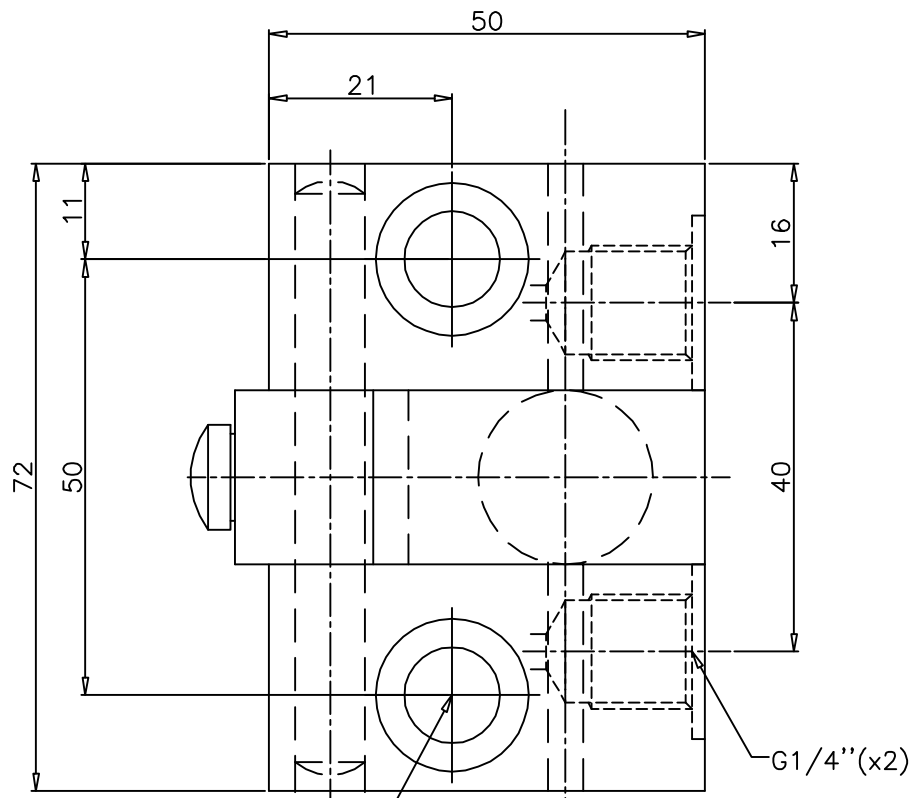
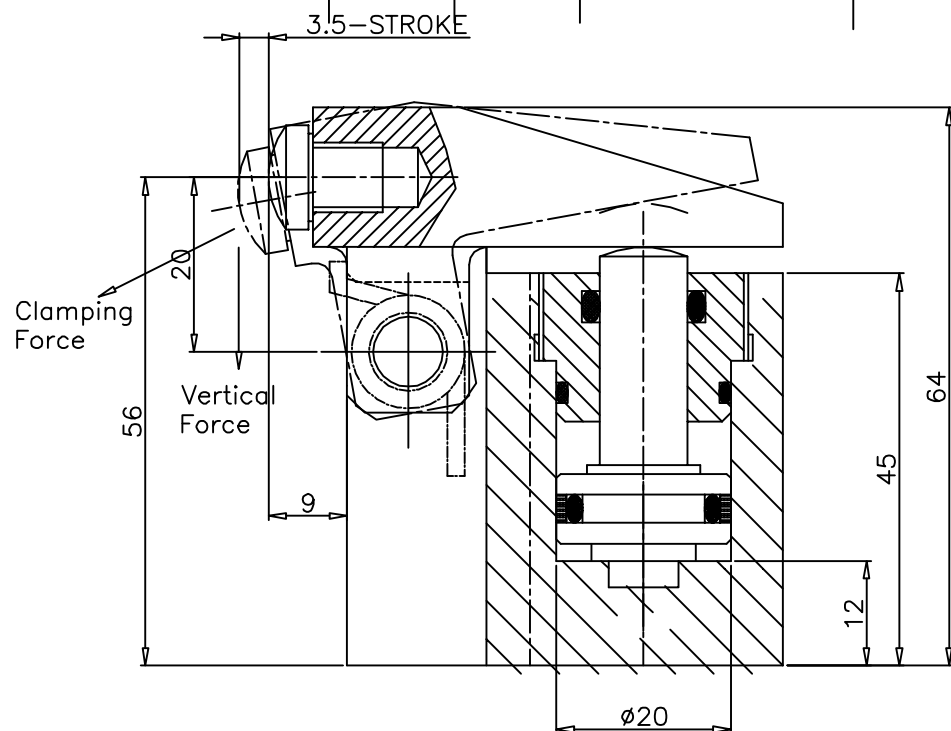

C'BORE ø17.5(X2)
ø11X8DEEP

Specification:-

Type : Low block cylinder. D/A
 Piston = 20 mm
 Vertical Stroke = 5 mm
 Horizontal Stroke = 3.5 mm
 Operating pressure : max 250 bar/min 10 bar
 Medium :Hydraulic oil
 (servo system HLP46/HLP68)

1.0 GENERAL

- 1.1 ALL DIMENSIONS ARE IN MM.
- 1.2 DO NOT SCALE THE DRG.IF IN DOUBT ASK.
- 1.3 SUBJECT TO CHANGE FOR IMPROVEMENT.

SURFACE FINISH														
Ra value	µm	0.025	0.05	0.1	0.2	0.4	0.8	1.6	3.2	6.3	12.5	25	50	100

GENERAL TOLERANCES WHERE NOT SPECIFIED

LINEAR - LENGTH OR DIAMETER						ANGULAR-LENGTH IN MM OF SHORT SIDE OF ∠			
0.5-6	6-30	30-120	120-315	315-1000	1000-2000	UPTO 6	6-30	30-120	120-400
±0.1	±0.2	±0.3	±0.5	±0.8	±1.2	±1'	±30'	±20'	±10'

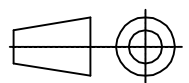

**QUICLOC
PVT LTD
B'lore - 70**

SCALE xxx	-	TITLE LOW BLOCK CYLINDER SINGLE ACTING TYPE-2	MATERIAL xxx	SHEET NO 1 OF 1
DESIGN TIRUMAL	DATE 27.08.08	MACHINE TYPE	GROUP NO.	REPLACES
DRAWN TIRUMAL		CUSTOMER:	SUPERCEDED BY -	-
CHECKED			DRAWING NO. A22301	
APPROVED				

1

2

3

4